



Typhoon HIL

# 4<sup>th</sup> Generation HIL.



## HIL606.

Speed, power and flexibility.  
Together as one.



[www.typhoon-hil.com](http://www.typhoon-hil.com)

# HIL606

The 4th Generation flagship has arrived.

## Robustness meets speed with future-proof connectivity options.

Approach physical tests of your control system with confidence. With the speed of our latest 4th generation devices, together with the power of our 6-series, 8-core processors, you can control more high-fidelity models than

ever before. And with new unique connectivity options, your controller won't know the difference between your test models and the devices in the field, no matter your use case.



**0.2**  $\mu$ s

Min. Simulation Step

**3.5** ns

DI Sampling Resolution

**24** <sub>(3PH)\*</sub>

Detailed DER Models

**16/8** <sub>(1PH/3PH)\*</sub>

Detailed Converter Models

**16** units

Paralleling

\*per HIL unit

## What's new?



Visit Typhoon HIL  
HIL606 website page.

- Upgrade in a flash with backwards compatibility for all devices and pin-to-pin compatibility with HIL604
- Model converters at timesteps as fast as 200 ns
- Down to 200 ns Analog Output update rate
- 3.5 ns Gate Drive System (GDS) Oversampling on all Digital Inputs
- Simulate your full microgrid with capacity for up to 24 Average Converter models
- Built-in M.2 slot for long-term data storage
- Unparalleled connectivity options:
  - 6 Ethernet ports, including 2 EtherCAT ports
  - 4 CAN ports, including 2 ports for flexible data rates (CAN FD)
  - 2 Quad-SFP (QSFP) ports

Now you have the **speed** you love from our latest 4<sup>th</sup> generation devices together with the **power** of our 6-series, 8-core processors, balanced with the **flexibility** you require to connect to the devices you need.

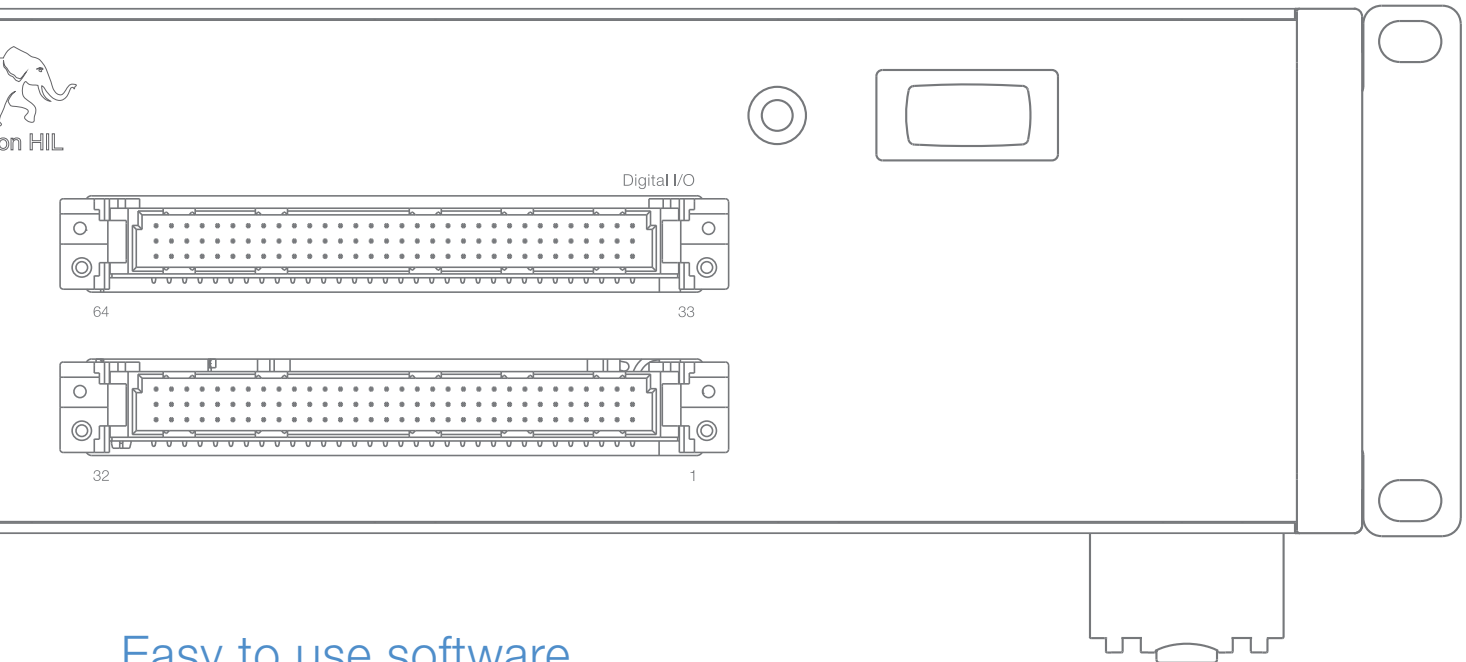

## Easy to use software toolchain.

Together with Typhoon HIL's easy to use software toolchain and top of the line support, you have the tools you need to perform rapid

control prototyping with sophisticated real-time test scenarios from the comfort of the office, no matter your experience level.

# Speed

for modeling and testing fast-switching converters.

SCADA demonstration of an EV DC Charger example running on a single HIL606 at 250ns timestep.

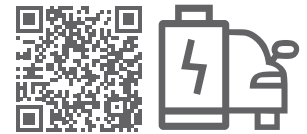

Learn more on Typhoon HIL e-Mobility website page.

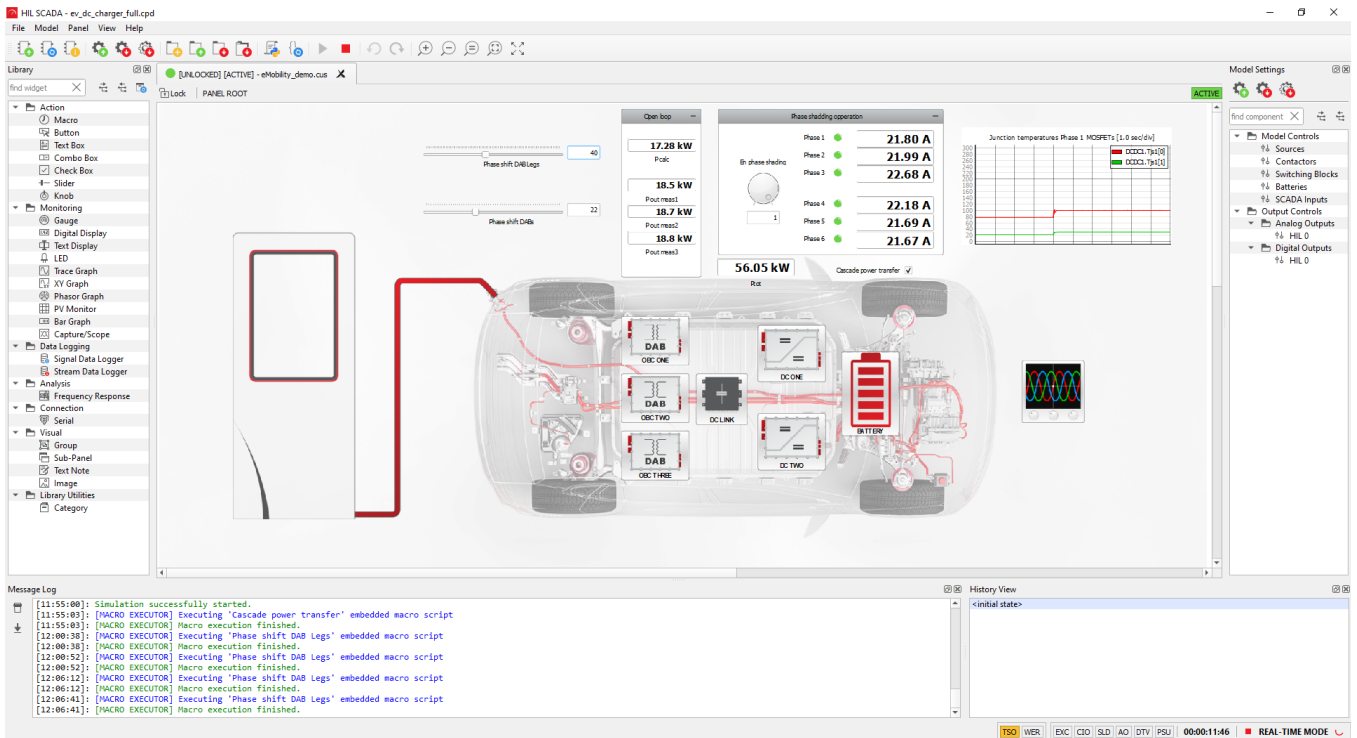

Early porting of the controller algorithm to the real hardware solves a large number of issues prior to system integration. This results in significant development time and cost savings.

[Read more:](#)



**Dr. Roland Greul**  
Manager of Department at AVL





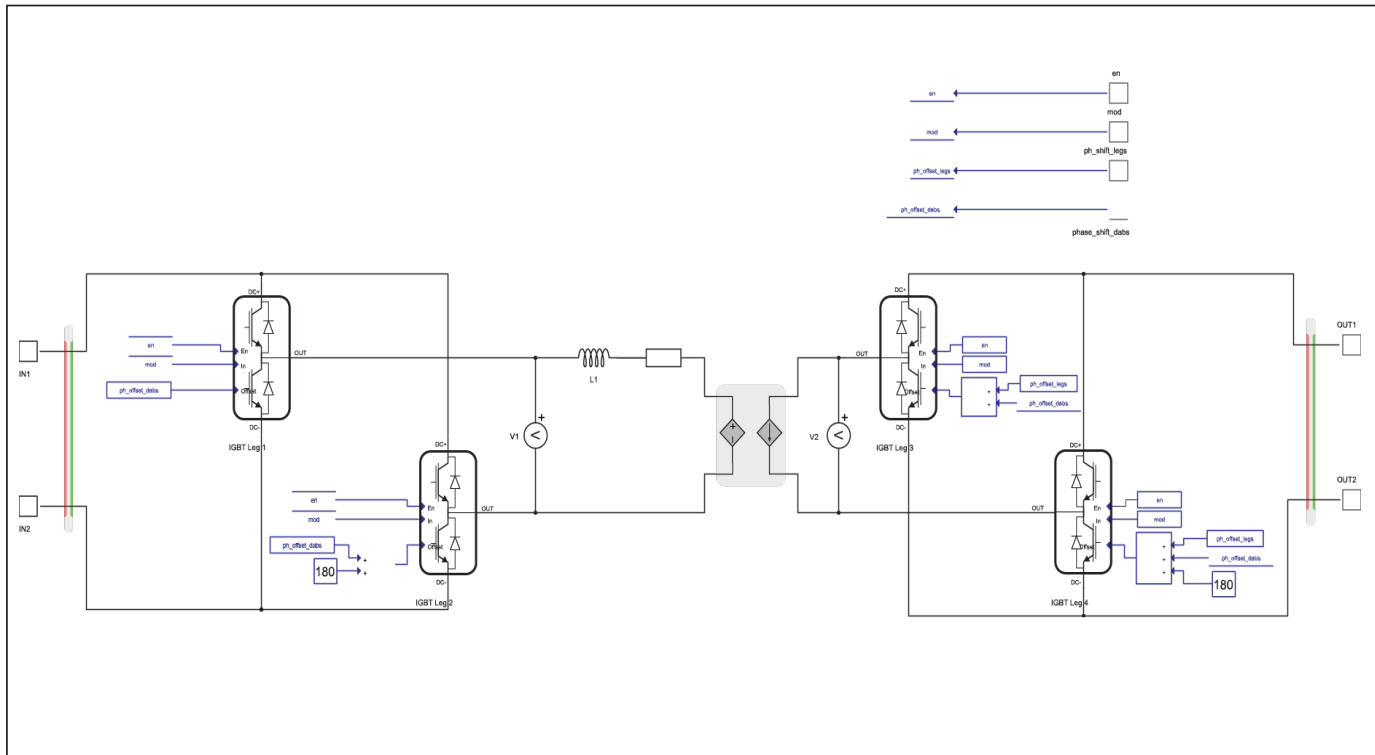

The model above represents 1 of 3 DC/DC high frequency isolation stages of the featured EV DC charging example, using 3 Dual Active Bridge (DAB) converters in parallel.

Need to model several dual-active bridges together at the highest switching frequencies?



With the HIL606, you can test many high-switching frequency complex converters with multi-module Si-C based converters between the 50 to 500 kHz range at once. With analog time resolution at 200 nanoseconds and greatly increased processing and IO capacity you have the tools you need to test your full electric drive or EV charging system in real-time with a single device.

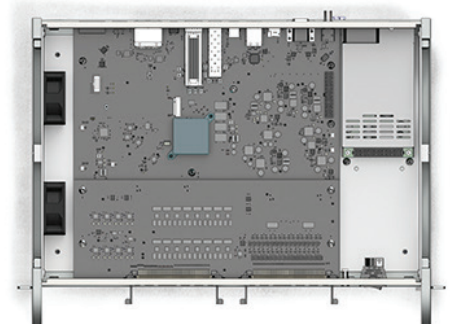

# Power

to run complex models at short timesteps.

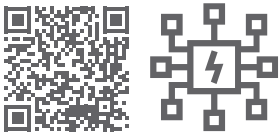

Learn more on Typhoon HIL Microgrid website page.

Worried your microgrid models are too complex to integrate real hardware and low-level controllers in your test setup?

The HIL606 supports 24 average distributed energy resource (DER) models in real-time at once, and at very short timesteps. This means you are extremely well-equipped for simulating full microgrid models in real-time with real equipment at the highest level of detail.

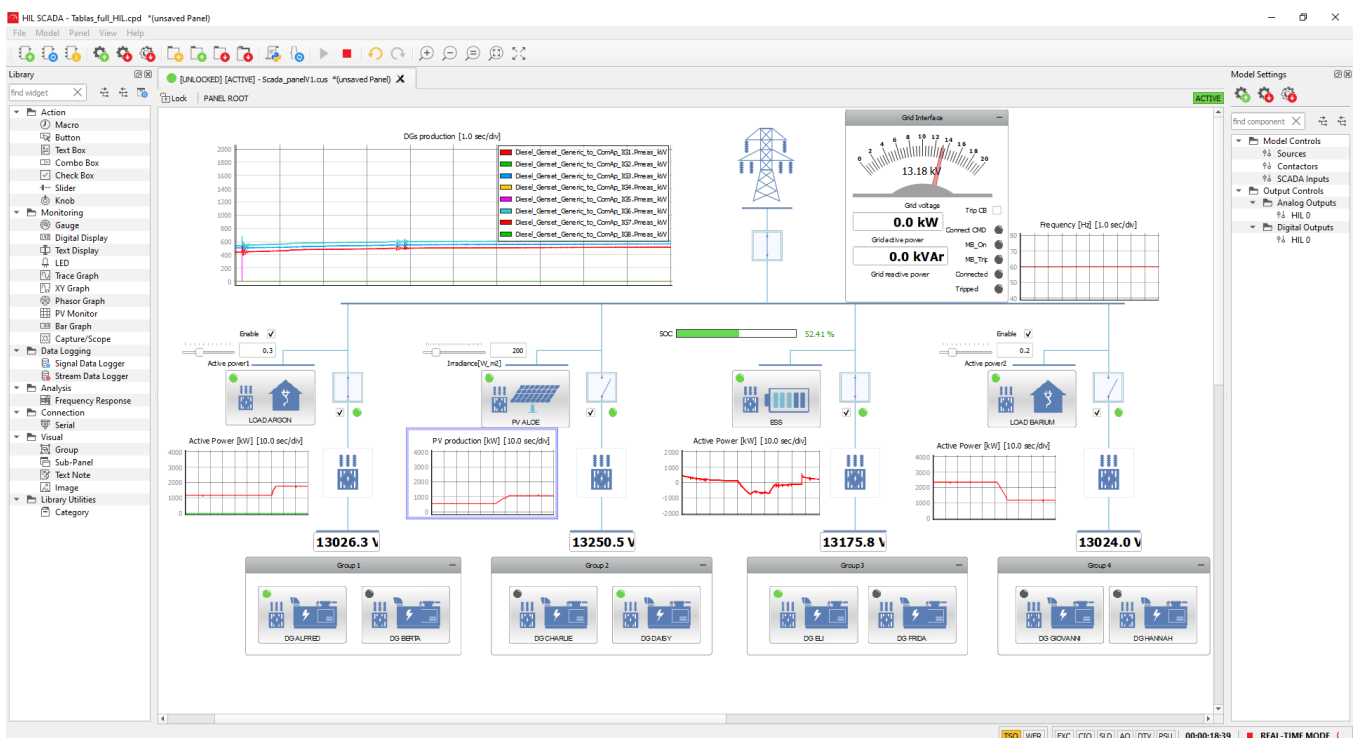

HIL SCADA demonstration of an islanded microgrid response to changes in DER production.

Read more:



We need a powerful real-time simulation platform in order to test our control system correctly.

**David Dunnett**  
Head of Software Development  
at Rolls-Royce Solutions

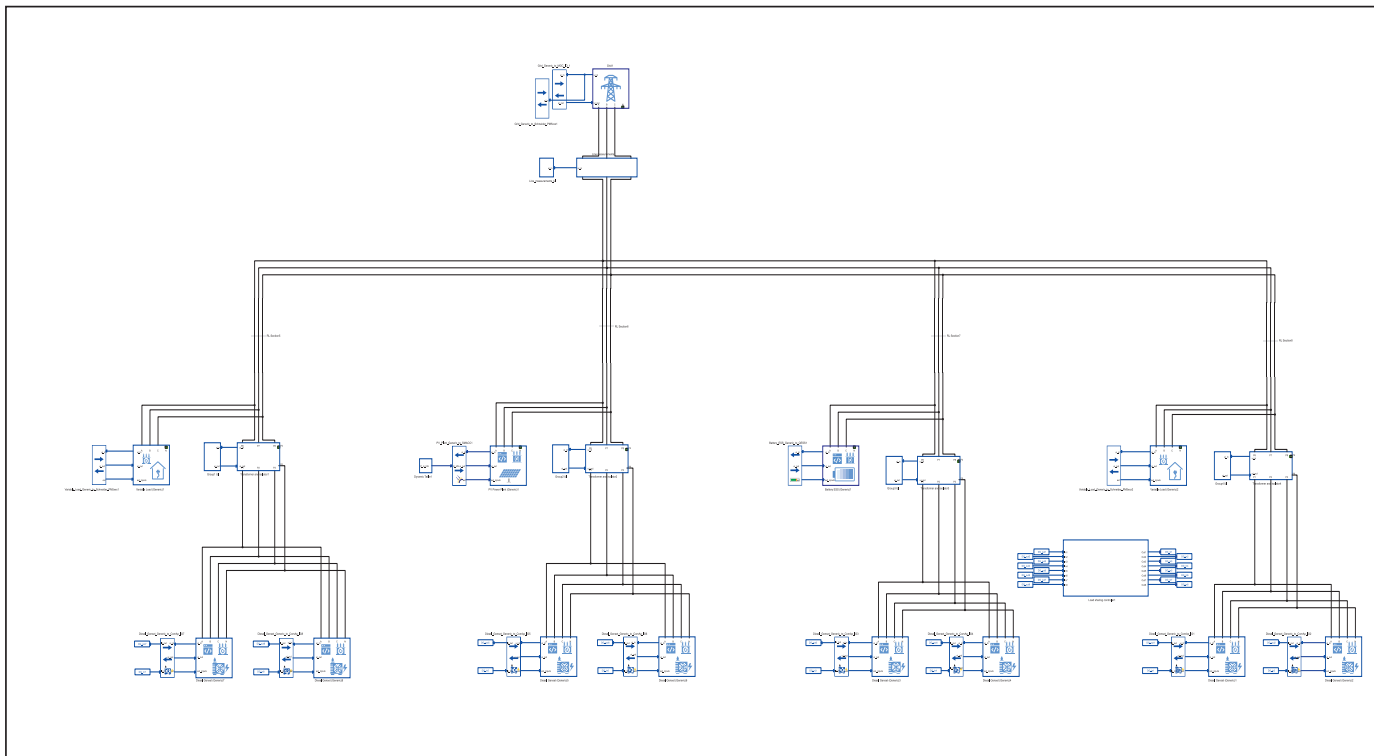

Example Rolls-Royce Solutions Berlin microgrid model setup for testing their mtu Microgrid Controller over Modbus TCP communication. This model uses only 4 of the HIL606's 8 available cores.

# Flexibility

to customize your testbed integration.

## Analog I/O

- 32 Analog Inputs and 64 Analog Outputs
- 200 ns minimum sampling resolution

## Digital I/O

- 64 Digital Inputs and 64 Digital Outputs
- 3.5 ns minimum oversampling resolution

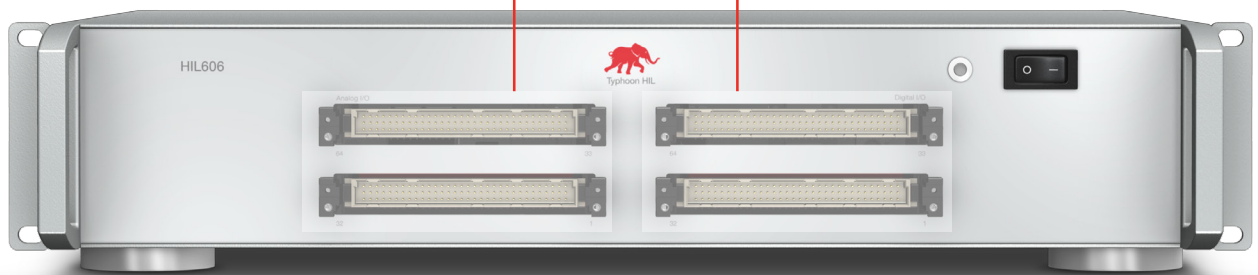

## 2 EtherCAT ports

- Hardware-supported slave interfaces
- Low latency daisy chaining with other EtherCAT devices



## 2 CAN + 2 CAN FD ports

- Double the connectivity options with CAN devices
- Full support for flexible data rates in CAN FD ports
- Ideal for e-Mobility



# Flexibility to customize your testbed integration. Best-in-class connectivity right out of the box.

Need flexible data rates for your CAN-connected vehicle components? Or just a faster response when connecting to third-party devices?

Now you can connect and use your HIL testbed with more flexibility than ever, thanks to completely new interfaces like EtherCat, CAN FD, and even an M.2 slot for long-term data storage. Expanded Quad Small Form-Factor Pluggable (QSFP) and Ethernet options give you strong support for low-level and time-critical internet-based protocols.

And of course, HIL606 is fully compatible with Typhoon HIL's growing portfolio of interface boards and devices, making connecting to power electronic devices, controllers, and even popular dSPACE and Texas Instruments devices possible right out of the box.

*"dSPACE" and "Texas Instruments" are registered trademarks of dSPACE GmbH and Texas Instruments Incorporated, respectively, in the United States of America or other countries, or both.*

## M.2 slot inside

Optional SSD for long-term offline data acquisition

## 4 Ethernet ports

The first HIL device to have 4 Ethernet ports for greater flexibility to support multiple networks and different protocols.

- 2 ports for high level protocols
  - Modbus, DNP3, OPC UA
  - Including THCC communication
- 2 ports for time critical protocols
  - IEC 61850 SV, Ethernet VE



## 2 SFP ports

- Communication with other devices only
- SFP Simulation Link capable

## 2 QSFP for paralleling

Connect 16 devices with more connection flexibility

- Bidirectional link
- Not required to close the ring

# Drive your tests faster than ever before.

E-mobility is fast, so its control systems must be faster. Testing performance requires criteria such as high dynamics, broad voltage ranges, and system stability despite rapidly changing loads and conditions.

The HIL606 was designed with these needs in mind. With timesteps as low as 200 nanoseconds and 3.5 nanoseconds digital oversampling resolution, MOSFET, IGBT

losses, and thermal losses can be modeled just as they would behave in the real device.

Best of all, with Typhoon HIL's complete solution, you don't need 3rd party software tools at any stage of the V-curve development. Still, the HIL606 does play well with others: direct compatibility with a wide array of existing software and hardware solutions mean you can easily start using HIL where you need it most.



We decided to use the Typhoon HIL hardware-in-the-loop simulation platform to shorten development time.

**Ryota Kitamoto**  
Engineer at Honda R&D



main processor  
**FPGA**



HIL606



**75%**  
faster



HIL604



co-processor  
**CPU**



HIL606



**10x**  
faster



HIL604



## Go wild with test cases.

Designing control systems for microgrids is a very delicate task. Controllers need to perform with a wide variety of devices and standards that continually evolve. Connected PV inverters can lose communication, even while the PV continues to inject energy into the grid.

With HIL, you have full control over the whole powerplant. You can test without any of the physical and safety constraints that come with real-world and power lab testing to see how the system responds in potentially catastrophic situations. You can address communication issues in advance by using the real protocols you will in the field. Powerful test automation tools make it easy to test as you develop.

In short, HIL606 lets you simulate more, faster.



We can get good test coverage of the system behavior and thereby have good confidence that the control solution we developed will work in a real plant scenario.

**Tilo Buehler**  
Global Product  
ManagerGrid Edge  
Solutions at Hitachi ABB



[Read more:](#)



analog and digital  
**IO**



HIL606



**2.5x**  
faster



HIL604



model capacity  
**DER**



HIL606



**2.4x**  
detailed  
3ph models



HIL604



# Uncompromising performance.

Parallel your HILs.  
Explode your potential.

Use the high-speed optical link to parallel your HIL606's while maintaining the small timestep. With the ability to parallel up to 16 units, you can model hundreds of detailed converter models in real-time without sacrificing model speed or model fidelity.

Easy connectivity options let you build a high performing P-HIL testbed in a day. Just connect the optical link interface to any amplifier and start emulating your powertrain or full microgrid.

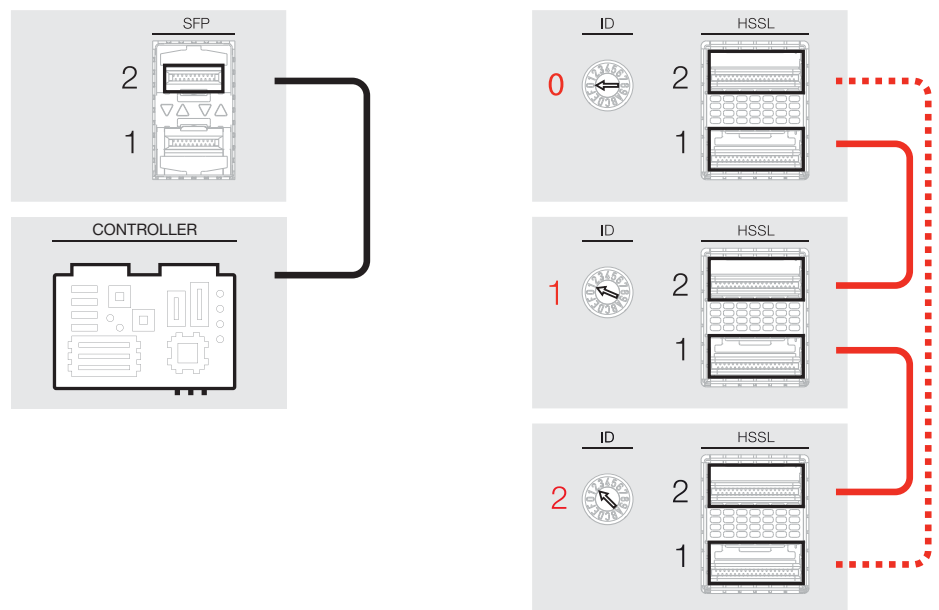
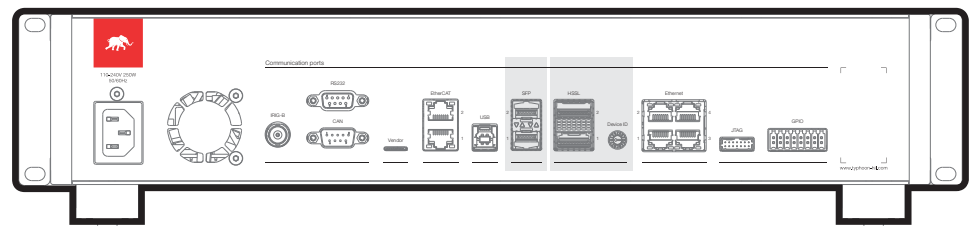

Four Small Form Factor Pluggable (SFP) ports:

- All can be used for paralleling
- Two QSFP ports allow for faster than ever paralleling capacity

I/O 16 64 256 ... and more! →



# HIL device comparison.



**HIL101**

**HIL404**

**HIL506**

**HIL606**

**Model capacity**

Maximum supported Ideal Converter Weight. <a href="#">Learn more</a>	6	12+	18+	24+
Detailed (switching) converter models (1ph / 3ph)	4 / 2	8 / 4	12 / 6	16 / 8
Machine Solvers supported (max.)	1	2+	4+	4+
Distribution network simulation	✓	✓	✓	✓

**Time resolution**

Minimal simulation step	250 ns	200 ns	200 ns	200 ns
DI sampling resolution	4.5 ns	3.5 ns	3.5 ns	3.5 ns

**IO**

Analog I/O per unit	16 / 16	16 / 16	16 / 32	32 / 64
Digital I/O per unit	32 / 32	32 / 32	64 / 64	64 / 64

**Connectivity**

Ethernet, USB 3.0, CAN, RS232, GPIO, HSSL	✓	✓	✓	✓
JTAG	✓	✓	✓	✓
Time synchronization (PPS and IRIG-B)			✓	✓
EtherCAT (master and slave)			✓	✓
FDCAN			✓	✓
SFP, QSFP			✓	✓

**Paralleling**

up to 4 units (HIL101)	up to 4 units (HIL404)	up to 16 units (HIL506 and HIL606)	up to 16 units (HIL506 and HIL606)
------------------------	------------------------	------------------------------------	------------------------------------

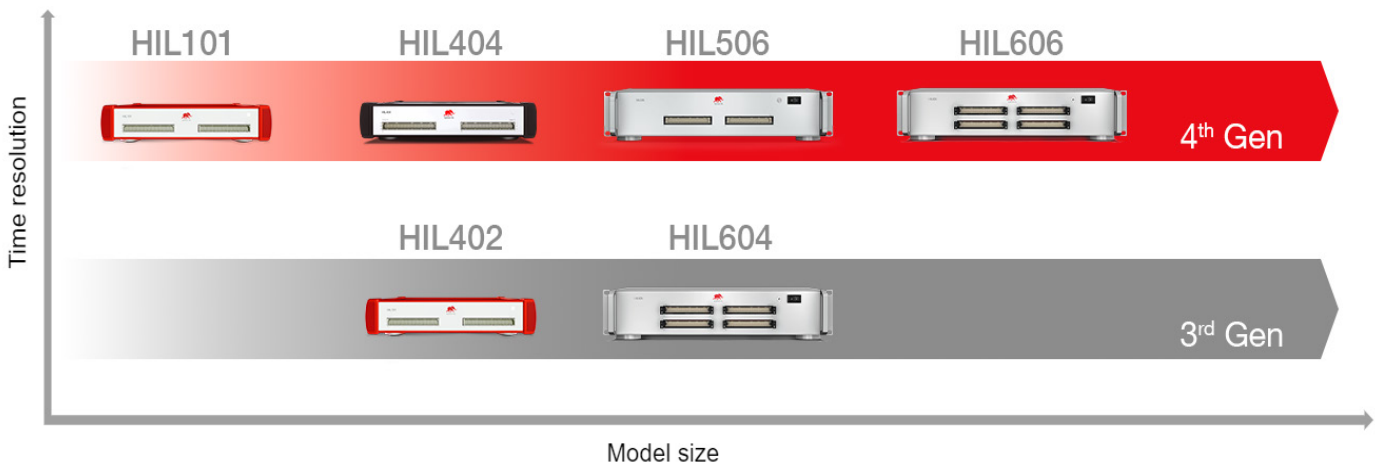

# HIL606 technical details.

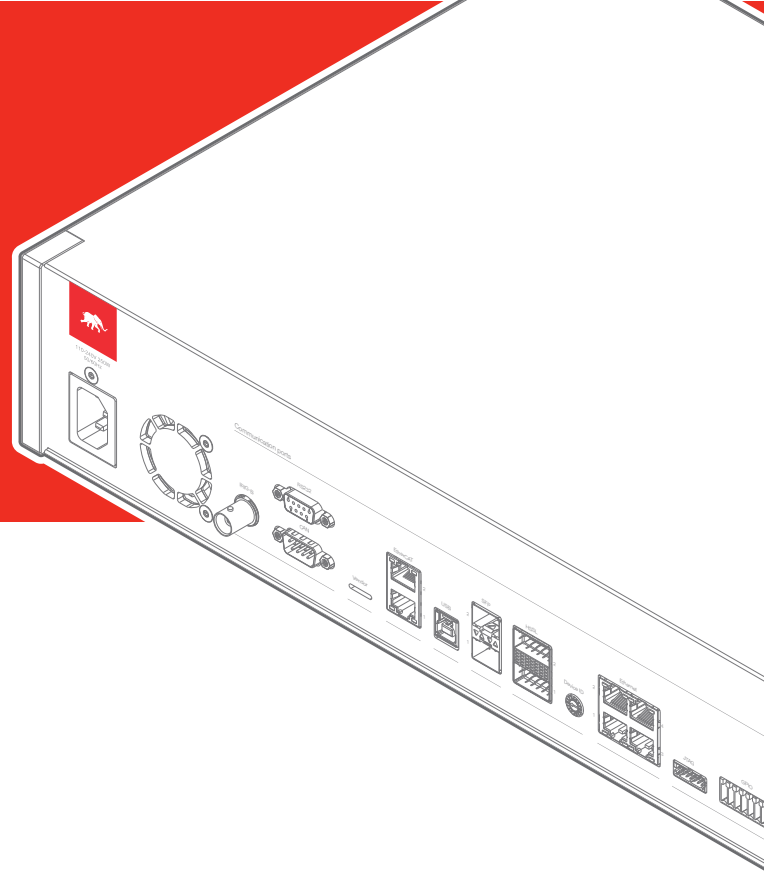

For more technical details  
read Typhoon HIL Hardware  
documentation.

<b>Processor</b>	Processor	ZU9EG Zynq UltraScale+ MPSoC
	Processor configurations	up to 8 processing cores
<b>Analog inputs (AI)</b>	Channels	32
	Resolution	16 bit ADC
	Input Voltage Range:	$\pm 10$ V
	Sample Rate	up to 1 MSPS
	Linearity (DNL/INL)	1/2
	Gain error / Offset error	0.01 % / 1 mV
	Input Resistance	$\sim 30$ k $\Omega$
	Protection	$\pm 24$ V tolerant, ESD protection
<b>Analog Outputs (AO)</b>	Channels	64
	Resolution	16 bit ADC
	Output Voltage Range	$\pm 10$ V
	Sample Rate	up to 5 MSPS
	Linearity (DNL/INL)	1/1
	Gain error / Offset error	0.01 % / 1 mV
	Output Resistance	$\sim 0$ $\Omega$
	Protection	$\pm 24$ V tolerant, ESD protection
<b>Analog IO connector</b>	Connector	DIN 41612, type C 96 pin male connector

<b>User Power Supply Stage (PSU)</b>	±5 V analog	up to 2 A, resettable protection
	±12 V analog	up to 2 A, resettable protection
	+3.3 V digital	up to 2 A, resettable protection
	+5 V digital	up to 2 A, resettable protection
<b>Digital inputs (DI)</b>	Channels	64 channels
	Input voltage range $V_i$	$-15\text{ V} < V_i < 15\text{ V}$
	Threshold voltages (low, high)	$(V_{iL}(\text{max}) = 0.8\text{ V}; V_{iH}(\text{min}) = 2\text{ V})$
	Input resistance	10 k $\Omega$
	Protection	±24 V tolerant, ESD protection
	DI sampling resolution	3.5 ns
<b>Digital outputs (DO)</b>	Channels	64 channels
	Output voltage range $V_o$	$0\text{ V} < V_o < 5\text{ V}$
	Threshold voltages (low, high)	$(V_{oL}(\text{max}) = 0.2\text{ V}; V_{oH}(\text{min}) = 4.8\text{ V})$
	Output resistance	430 $\Omega$
	Protection	±24 V tolerant, ESD protection
<b>Digital IO connector</b>	Connector type	DIN 41612, type C 96 pin male connector
<b>Connectivity</b>	Ethernet	4x RJ45 connectors; 10/100/1000 Mbps
	USB 3.0	1x type B connector
	CAN	2x DE9 male Connector
	FDCAN	2x DE9 male Connector
	RS232	DE9 Female Connector
	High speed serial link	
	Quad SFP	
	JTAG	Molex 87833-1420
	GPIO	12+ multi-purpose IO pins, terminal blocks
	EtherCAT	2x
Time synchronization (IRIG-B)	1x	
<b>Housing</b>	Dimensions	19" rack mountable; 2U height
	Weight	up to 10 kg
<b>Power supply</b>	Input voltage	100 - 250 VAC
	Power consumption	up to 250 W



Typhoon HIL

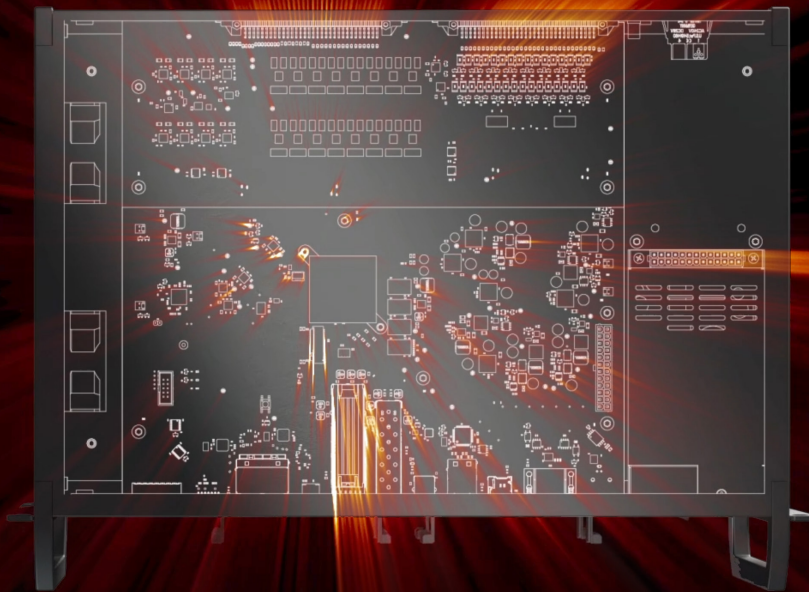

Typhoon HIL, Inc.  
15 Ward Street, 2nd Floor  
Somerville, MA 02143  
USA

Phone: +1 800-766-3181

Typhoon HIL GmbH.  
Seminarstrasse 85  
CH-5430 Wettingen  
Aargau, Switzerland

Phone: +41 (0)56 521 00 25

Tajfun HIL d.o.o.  
Bajci Zilinskog bb  
21000 Novi Sad  
Republic of Serbia

Phone: +381 21 3010 476

[www.typhoon-hil.com](http://www.typhoon-hil.com)  
e-mail: [info@typhoon-hil.com](mailto:info@typhoon-hil.com)